

Arquitectura de Computadores

Capítulo 5. Almacenamiento y otros aspectos de la E/S

Based on the original material of the book:
D.A. Patterson y J.L. Hennessy "Computer Organization and Design:
The Hardware/Software Interface" 4th edition.

Escuela Politécnica Superior
Universidad Autónoma de Madrid

Profesores:

G130 y G131: Iván González Martínez

CLASES PARTICULARES, TUTORIAS TECNICAS ONLINE
LLAMA O ENVIA WHATSAPP: 689 45 44 70

ONLINE PRIVATE LESSONS FOR SCIENCE STUDENTS
CALL OR WHATSAPP:689 45 44 70

Cartagena99

Introduction

- I/O devices can be characterized by
 - Behaviour: input, output, storage
 - Partner: human or machine
 - Data rate: bytes/sec, transfers/sec
- I/O bus connections

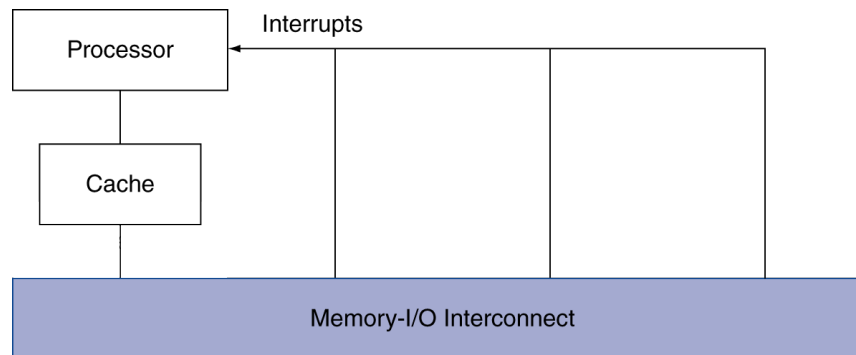

Cartagena99

CLASES PARTICULARES, TUTORÍAS TÉCNICAS ONLINE
LLAMA O ENVÍA WHATSAPP: 689 45 44 70

ONLINE PRIVATE LESSONS FOR SCIENCE STUDENTS
CALL OR WHATSAPP:689 45 44 70

I/O System Characteristics

- Dependability is important
 - Particularly for storage devices
- Performance measures
 - Latency (response time)
 - Throughput (bandwidth)
 - Desktops & embedded systems
 - Mainly interested in response time & diversity of devices
 - Servers

Cartagena99

CLASES PARTICULARES, TUTORÍAS TÉCNICAS ONLINE
LLAMA O ENVÍA WHATSAPP: 689 45 44 70

- - -

ONLINE PRIVATE LESSONS FOR SCIENCE STUDENTS
CALL OR WHATSAPP:689 45 44 70

Dependability Measures

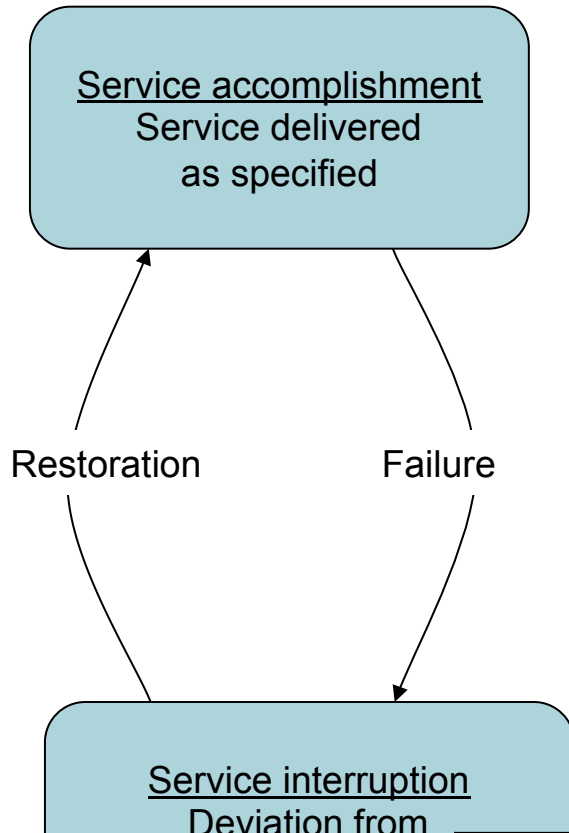

- Reliability: mean time to failure (MTTF)
- Service interruption: mean time to repair (MTTR)
- Mean time between failures
 - $MTBF = MTTF + MTTR$
- Availability = $MTTF / (MTTF + MTTR)$
- Improving Availability
 - Increase MTTF: fault avoidance, fault tolerance, fault forecasting
 - Reduce MTTR: improved tools and processes for diagnosis and

Cartagena99

CLASES PARTICULARES, TUTORÍAS TÉCNICAS ONLINE
LLAMA O ENVÍA WHATSAPP: 689 45 44 70

ONLINE PRIVATE LESSONS FOR SCIENCE STUDENTS
CALL OR WHATSAPP: 689 45 44 70

Disk Storage

- Nonvolatile, rotating magnetic storage

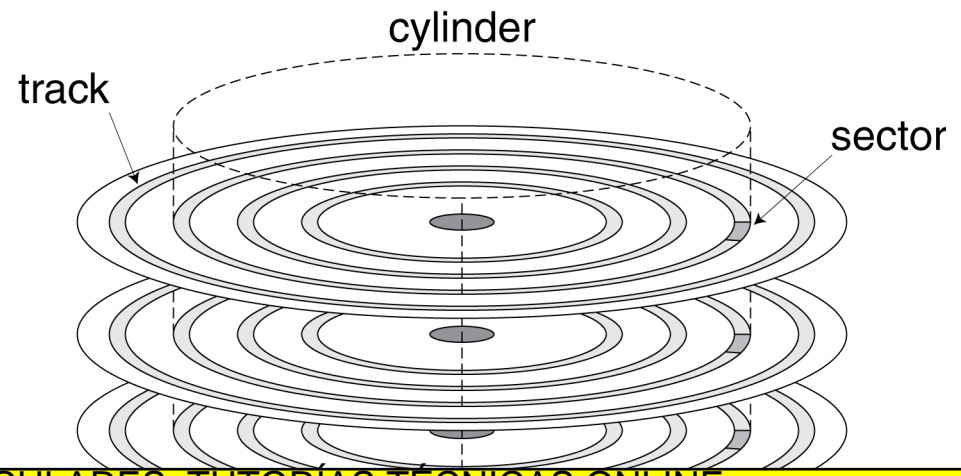

CLASES PARTICULARES, TUTORÍAS TÉCNICAS ONLINE
LLAMA O ENVÍA WHATSAPP: 689 45 44 70

ONLINE PRIVATE LESSONS FOR SCIENCE STUDENTS
CALL OR WHATSAPP:689 45 44 70

Cartagena99

Disk Sectors and Access

- Each sector records
 - Sector ID
 - Data (512 bytes, 4096 bytes proposed)
 - Error correcting code (ECC)
 - Used to hide defects and recording errors
 - Synchronization fields and gaps
- Access to a sector involves
 - Queuing delay if other accesses are pending
 - Seek: move the heads
 - Rotational latency

Cartagena99

CLASES PARTICULARES, TUTORÍAS TÉCNICAS ONLINE
LLAMA O ENVIA WHATSAPP: 689 45 44 70

ONLINE PRIVATE LESSONS FOR SCIENCE STUDENTS
CALL OR WHATSAPP:689 45 44 70

Disk Access Example

- Given
 - 512B sector, 15,000rpm, 4ms average seek time, 100MB/s transfer rate, 0.2ms controller overhead, idle disk
- Average read time
 - 4ms seek time
 - + $\frac{1}{2} / (15,000/60) = 2\text{ms}$ rotational latency
 - + $512 \text{ B} / 100\text{MB/s} = 0.005\text{ms}$ transfer time
 - + 0.2ms controller delay
 - = 6.2ms
- If actual average seek time is 1ms

Cartagena99

CLASES PARTICULARES, TUTORIAS TECNICAS ONLINE
LLAMA O ENVIA WHATSAPP: 689 45 44 70

ONLINE PRIVATE LESSONS FOR SCIENCE STUDENTS
CALL OR WHATSAPP:689 45 44 70

RAID

- Redundant Array of Inexpensive (Independent) Disks
 - Use multiple smaller disks (c.f. one large disk)
 - Parallelism improves performance
 - Plus extra disk(s) for redundant data storage
- Provides fault tolerant storage system
 - Especially if failed disks can be “hot swapped”
- RAID 0
 - No redundancy (“AID”?)

Just stripe data over multiple disks

Cartagena99

CLASES PARTICULARES, TUTORIAS TECNICAS ONLINE
LLAMA O ENVIA WHATSAPP: 689 45 44 70

ONLINE PRIVATE LESSONS FOR SCIENCE STUDENTS
CALL OR WHATSAPP:689 45 44 70

RAID 1 & 2

- RAID 1: Mirroring
 - N + N disks, replicate data
 - Write data to both data disk and mirror disk
 - On disk failure, read from mirror
- RAID 2: Error correcting code (ECC)
 - N + E disks (e.g., 10 + 4)
 - Split data at bit level across N disks
 - Generate E-bit ECC

Cartagena99

CLASES PARTICULARES, TUTORÍAS TÉCNICAS ONLINE
LLAMA O ENVÍA WHATSAPP: 689 45 44 70

- - -

ONLINE PRIVATE LESSONS FOR SCIENCE STUDENTS
CALL OR WHATSAPP:689 45 44 70

RAID 3: Bit-Interleaved Parity

- N + 1 disks
 - Data striped across N disks at byte level
 - Redundant disk stores parity
 - Read access
 - Read all disks
 - Write access
 - Generate new parity and update all disks
 - On failure

Cartagena99

CLASES PARTICULARES, TUTORIAS TECNICAS ONLINE
LLAMA O ENVIA WHATSAPP: 689 45 44 70

ONLINE PRIVATE LESSONS FOR SCIENCE STUDENTS
CALL OR WHATSAPP:689 45 44 70

RAID 4: Block-Interleaved Parity

- N + 1 disks
 - Data striped across N disks at block level
 - Redundant disk stores parity for a group of blocks
 - Read access
 - Read only the disk holding the required block
 - Write access
 - Just read disk containing modified block, and parity disk
 - Calculate new parity, update data disk and parity disk
 - On failure
 - Use parity to reconstruct missing data

Cartagena99

CLASES PARTICULARES, TUTORÍAS TÉCNICAS ONLINE
LLAMA O ENVÍA WHATSAPP: 689 45 44 70

- - -

ONLINE PRIVATE LESSONS FOR SCIENCE STUDENTS
CALL OR WHATSAPP:689 45 44 70

RAID 3 vs RAID 4

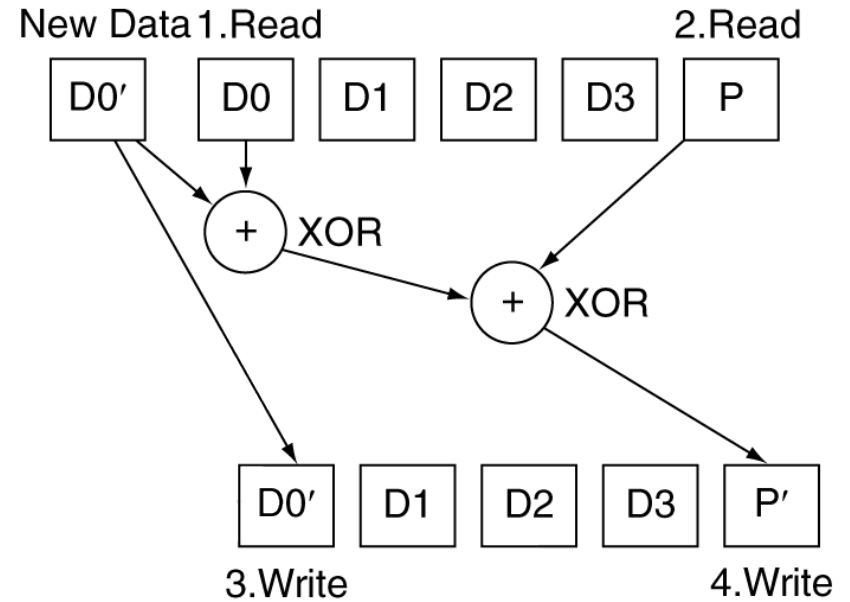
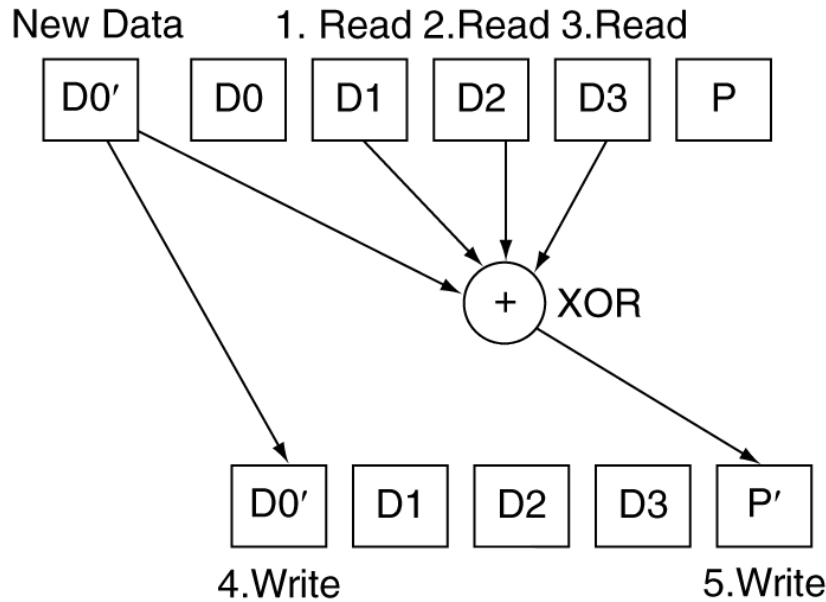

Cartagena99

CLASES PARTICULARES, TUTORÍAS TÉCNICAS ONLINE
 LLAMA O ENVÍA WHATSAPP: 689 45 44 70

ONLINE PRIVATE LESSONS FOR SCIENCE STUDENTS
 CALL OR WHATSAPP: 689 45 44 70

RAID 5: Distributed Parity

- N + 1 disks
 - Like RAID 4, but parity blocks distributed across disks
 - Avoids parity disk being a bottleneck
- Widely used

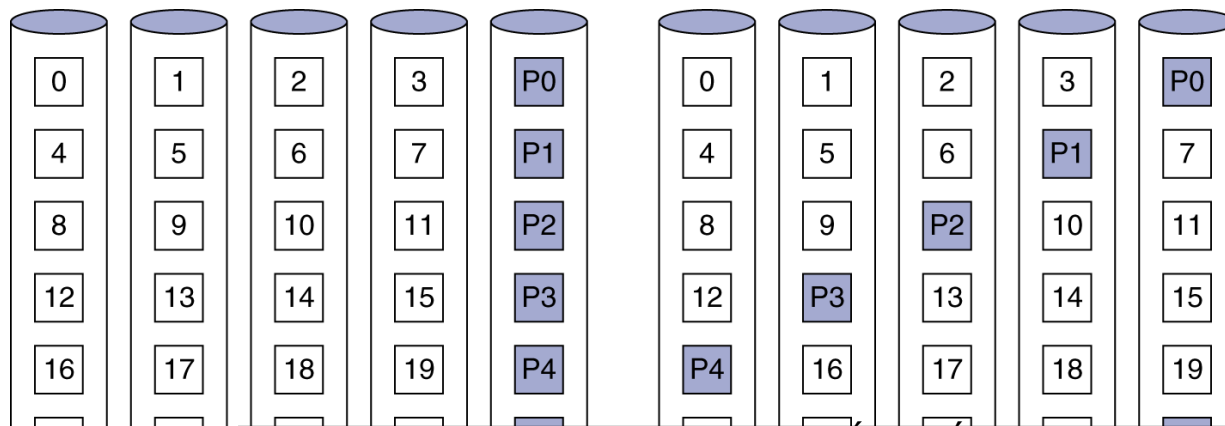

Cartagena99

CLASES PARTICULARES, TUTORÍAS TÉCNICAS ONLINE
LLAMA O ENVÍA WHATSAPP: 689 45 44 70

ONLINE PRIVATE LESSONS FOR SCIENCE STUDENTS
CALL OR WHATSAPP:689 45 44 70

RAID 6: P + Q Redundancy

- N + 2 disks
 - Like RAID 5, but two lots of parity
 - Greater fault tolerance through more redundancy
- Multiple RAID
 - More advanced systems give similar fault tolerance with better performance

Cartagena99

CLASES PARTICULARES, TUTORÍAS TÉCNICAS ONLINE
LLAMA O ENVÍA WHATSAPP: 689 45 44 70

ONLINE PRIVATE LESSONS FOR SCIENCE STUDENTS
CALL OR WHATSAPP:689 45 44 70

RAID Summary

- RAID can improve performance and availability
 - High availability requires hot swapping
- Assumes independent disk failures
 - Too bad if the building burns down!
- See “Hard Disk Performance, Quality and Reliability”
 - <http://www.pcguide.com/ref/hdd/perf/index.htm>

Cartagena99

CLASES PARTICULARES, TUTORÍAS TÉCNICAS ONLINE
LLAMA O ENVÍA WHATSAPP: 689 45 44 70

ONLINE PRIVATE LESSONS FOR SCIENCE STUDENTS
CALL OR WHATSAPP:689 45 44 70

Flash Storage

- Nonvolatile semiconductor storage
 - 100× – 1000× faster than disk
 - Smaller, lower power, more robust
 - But more \$/GB (between disk and DRAM)

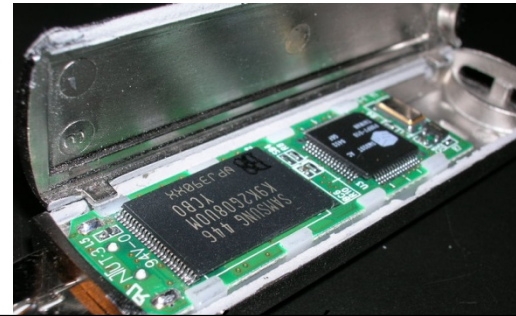

Cartagena99

CLASES PARTICULARES, TUTORIAS TECNICAS ONLINE
LLAMA O ENVIA WHATSAPP: 689 45 44 70

ONLINE PRIVATE LESSONS FOR SCIENCE STUDENTS
CALL OR WHATSAPP:689 45 44 70

Flash Types

- NOR flash: bit cell like a NOR gate
 - Random read/write access
 - Used for instruction memory in embedded systems
- NAND flash: bit cell like a NAND gate
 - Denser (bits/area), but block-at-a-time access
 - Cheaper per GB
 - Used for USB keys, media storage, ...
- Flash bits wears out after 1000' s of accesses
 - Not suitable for direct RAM or disk replacement

Cartagena99

CLASES PARTICULARES, TUTORÍAS TÉCNICAS ONLINE
LLAMA O ENVÍA WHATSAPP: 689 45 44 70

ONLINE PRIVATE LESSONS FOR SCIENCE STUDENTS
CALL OR WHATSAPP:689 45 44 70

Interconnecting Components

- Need interconnections between
 - CPU, memory, I/O controllers
- Bus: shared communication channel
 - Parallel set of wires for data and synchronization of data transfer
 - Can become a bottleneck
- Performance limited by physical factors
 - Wire length, number of connections
- More recent alternative: high-speed serial connections with switches

Cartagena99

CLASES PARTICULARES, TUTORÍAS TÉCNICAS ONLINE
LLAMA O ENVÍA WHATSAPP: 689 45 44 70

ONLINE PRIVATE LESSONS FOR SCIENCE STUDENTS
CALL OR WHATSAPP:689 45 44 70

Bus Types

- Processor-Memory buses
 - Short, high speed
 - Design is matched to memory organization
- I/O buses
 - Longer, allowing multiple connections
 - Specified by standards for interoperability
 - Connect to processor-memory bus through a bridge

Cartagena99

CLASES PARTICULARES, TUTORÍAS TÉCNICAS ONLINE
LLAMA O ENVIA WHATSAPP: 689 45 44 70

ONLINE PRIVATE LESSONS FOR SCIENCE STUDENTS
CALL OR WHATSAPP:689 45 44 70

Bus Signals and Synchronization

- Data lines
 - Carry address and data
 - Multiplexed or separate
- Control lines
 - Indicate data type, synchronize transactions
- Synchronous
 - Uses a bus clock
- Asynchronous

Cartagena99

CLASES PARTICULARES, TUTORIAS TECNICAS ONLINE
LLAMA O ENVIA WHATSAPP: 689 45 44 70

ONLINE PRIVATE LESSONS FOR SCIENCE STUDENTS
CALL OR WHATSAPP:689 45 44 70

I/O Bus Examples

	Firewire	USB 2.0	PCI Express	Serial ATA	Serial Attached SCSI
Intended use	External	External	Internal	Internal	External
Devices per channel	63	127	1	1	4
Data width	4	2	2/lane	4	4
Peak bandwidth	50MB/s or 100MB/s	0.2MB/s, 1.5MB/s, or 60MB/s	250MB/s/lane 1×, 2×, 4×, 8×, 16×, 32×	300MB/s	300MB/s
Hot pluggable	Yes	Yes	Depends	Yes	Yes
Max length	4.5m	5m	0.5m	1m	8m
Standard	IEEE 1394	USB	PCIe	SATA	SCSI

Cartagena99

CLASES PARTICULARES, TUTORIAS TÉCNICAS ONLINE
LLAMA O ENVIA WHATSAPP: 689 45 44 70

ONLINE PRIVATE LESSONS FOR SCIENCE STUDENTS
CALL OR WHATSAPP:689 45 44 70

I/O Bus Examples

	Firewire	USB 2.0	PCI Express	Serial ATA	Serial Attached SCSI
Intended use	External	External	Internal	Internal	External
Devices per channel	63	127	1	1	4
Data width	4	2	2/lane	4	4
Peak bandwidth	50MB/s or 100MB/s	0.2MB/s, 1.5MB/s, or 60MB/s	250MB/s/lane 1×, 2×, 4×, 8×, 16×, 32×	300MB/s	300MB/s
Hot pluggable	Yes	Yes	Depends	Yes	Yes
Max length	4.5m	5m	0.5m	1m	8m
Standard	IEEE 1394	USB	PCIe	SATA	SCSI

Cartagena99

CLASES PARTICULARES, TUTORIAS TÉCNICAS ONLINE
LLAMA O ENVIA WHATSAPP: 689 45 44 70

ONLINE PRIVATE LESSONS FOR SCIENCE STUDENTS
CALL OR WHATSAPP:689 45 44 70

Processor/core Interconnect Buses

Quick Path Interconnect (QPI)

Versión Intel QuickPath Interconnect	Año	Frecuencia max.	Ancho enlace max.	Ancho de banda agregado max. (bidireccional)	Ancho de banda max. 16-Bit (unidireccional)*
1.0	2008	3,2 GHz	20 Bit	25,6 GB/s	12,8 GB/s

HyperTransport (HT)

HyperTransport version	Year	Max. HT frequency	Max. link width	Max. aggregate bandwidth (bi-directional)	Max. bandwidth at 16-bit unidirectional (GB/s)	Max. bandwidth at 32-bit unidirectional* (GB/s)
1.0	2001	800 MHz	32-bit	12.8 GB/s	3.2	6.4
1.1	2002	800 MHz	32-bit	12.8 GB/s	3.2	6.4
2.0	2004	1.4 GHz	32-bit	22.4 GB/s	5.6	11.2
3.0	2006	2.6 GHz	32-bit	41.6 GB/s	10.4	20.8
3.1	2008	3.2 GHz	32-bit	51.2 GB/s	12.8	25.6

Cartagena99

CLASES PARTICULARES, TUTORIAS TÉCNICAS ONLINE
LLAMA O ENVIA WHATSAPP: 689 45 44 70

ONLINE PRIVATE LESSONS FOR SCIENCE STUDENTS
CALL OR WHATSAPP:689 45 44 70

System Architecture

Single Processor - Intel

- Depends on the microprocessor architecture and the chipset manufacturer

Intel Core i7

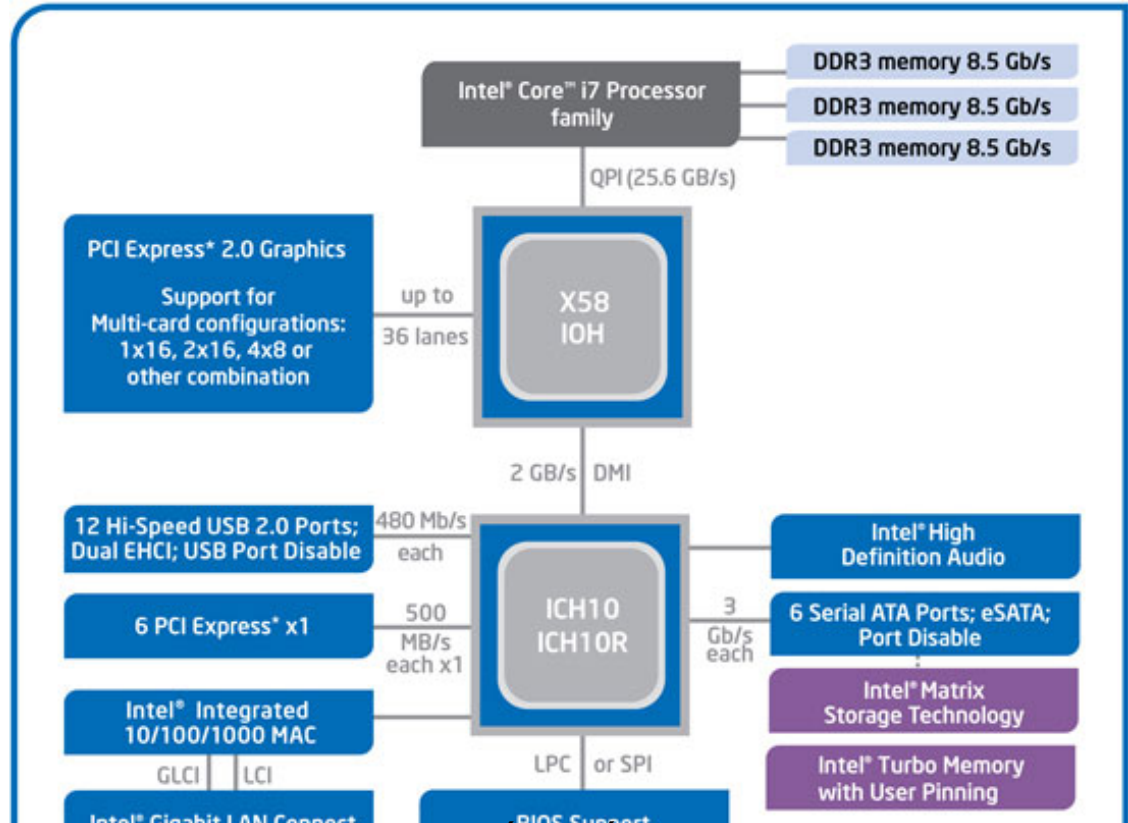

CLASES PARTICULARES, TUTORIAS TECNICAS ONLINE
LLAMA O ENVIA WHATSAPP: 689 45 44 70

ONLINE PRIVATE LESSONS FOR SCIENCE STUDENTS
CALL OR WHATSAPP:689 45 44 70

Cartagena99

System Architecture

Dual Processor - AMD



NVIDIA nForce® 680a SLI™ System Architecture
Motherboard Works with 1 or 2 CPUs

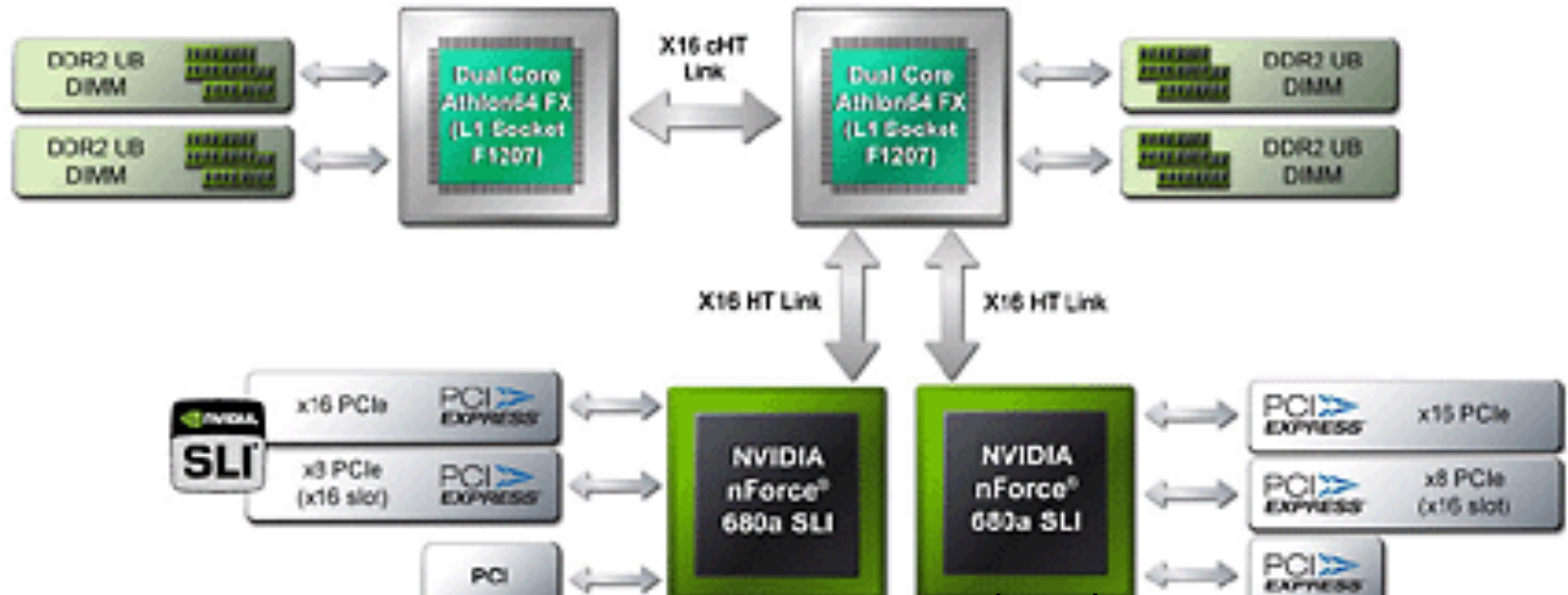

Cartagena99

CLASES PARTICULARES, TUTORÍAS TÉCNICAS ONLINE
LLAMA O ENVÍA WHATSAPP: 689 45 44 70

ONLINE PRIVATE LESSONS FOR SCIENCE STUDENTS
CALL OR WHATSAPP: 689 45 44 70

I/O Management

- I/O is mediated by the OS
 - Multiple programs share I/O resources
 - Need protection and scheduling
 - I/O causes asynchronous interrupts
 - Same mechanism as exceptions
 - I/O programming is fiddly
 - OS provides abstractions to programs

The logo for Cartagena99, featuring the text "Cartagena99" in a stylized, green, serif font. The text is set against a light blue and orange gradient background that resembles a stylized wave or a banner.

CLASES PARTICULARES, TUTORÍAS TÉCNICAS ONLINE
LLAMA O ENVÍA WHATSAPP: 689 45 44 70

- - -

ONLINE PRIVATE LESSONS FOR SCIENCE STUDENTS
CALL OR WHATSAPP:689 45 44 70

I/O Commands

- I/O devices are managed by I/O controller hardware
 - Transfers data to/from device
 - Synchronizes operations with software
- Command registers
 - Cause device to do something (read, write)
- Status registers
 - Indicate what the device is doing and occurrence of errors
- Data registers

Cartagena99

CLASES PARTICULARES, TUTORÍAS TÉCNICAS ONLINE
LLAMA O ENVIA WHATSAPP: 689 45 44 70

- - -

ONLINE PRIVATE LESSONS FOR SCIENCE STUDENTS
CALL OR WHATSAPP:689 45 44 70

I/O Register Mapping

- Memory mapped I/O
 - Registers are addressed in same space as memory
 - Address decoder distinguishes between them
 - OS uses address translation mechanism to make them only accessible to kernel
- I/O instructions
 - Separate instructions to access I/O registers

Cartagena99

CLASES PARTICULARES, TUTORÍAS TÉCNICAS ONLINE
LLAMA O ENVÍA WHATSAPP: 689 45 44 70

ONLINE PRIVATE LESSONS FOR SCIENCE STUDENTS
CALL OR WHATSAPP:689 45 44 70

Polling

- Periodically check I/O status register
 - If device ready, do operation
 - If error, take action
- Common in small or low-performance real-time embedded systems
 - Predictable timing
 - Low hardware cost
- In other systems, wastes CPU time

Cartagena99

CLASES PARTICULARES, TUTORÍAS TÉCNICAS ONLINE
LLAMA O ENVÍA WHATSAPP: 689 45 44 70

- - -

ONLINE PRIVATE LESSONS FOR SCIENCE STUDENTS
CALL OR WHATSAPP:689 45 44 70

Interrupts

- When a device is ready or error occurs
 - Controller interrupts CPU
- Interrupt is like an exception
 - But not synchronized to instruction execution
 - Can invoke handler between instructions
 - Cause information often identifies the interrupting device
- Priority interrupts
 - Devices needing more urgent attention get higher priority

Cartagena99

CLASES PARTICULARES, TUTORÍAS TÉCNICAS ONLINE
LLAMA O ENVÍA WHATSAPP: 689 45 44 70

ONLINE PRIVATE LESSONS FOR SCIENCE STUDENTS
CALL OR WHATSAPP:689 45 44 70

I/O Data Transfer

- Polling and interrupt-driven I/O
 - CPU transfers data between memory and I/O data registers
 - Time consuming for high-speed devices
- Direct memory access (DMA)
 - OS provides starting address in memory
 - I/O controller transfers to/from memory autonomously

Cartagena99

CLASES PARTICULARES, TUTORÍAS TÉCNICAS ONLINE
LLAMA O ENVÍA WHATSAPP: 689 45 44 70

ONLINE PRIVATE LESSONS FOR SCIENCE STUDENTS
CALL OR WHATSAPP:689 45 44 70

DMA/Cache Interaction

- If DMA writes to a memory block that is cached
 - Cached copy becomes stale
- If write-back cache has dirty block, and DMA reads memory block
 - Reads stale data
- Need to ensure cache coherence
 - Flush blocks from cache if they will be used for DMA
 - Or use non-cacheable memory locations for I/O

Cartagena99

CLASES PARTICULARES, TUTORÍAS TÉCNICAS ONLINE
LLAMA O ENVÍA WHATSAPP: 689 45 44 70

- - -

ONLINE PRIVATE LESSONS FOR SCIENCE STUDENTS
CALL OR WHATSAPP:689 45 44 70

DMA/VMM Interaction

- OS uses virtual addresses for memory
 - DMA blocks may not be contiguous in physical memory
- Should DMA use virtual addresses?
 - Would require controller to do translation
- If DMA uses physical addresses
 - May need to break transfers into page-sized chunks
 - Or chain multiple transfers

Cartagena99

CLASES PARTICULARES, TUTORÍAS TÉCNICAS ONLINE
LLAMA O ENVÍA WHATSAPP: 689 45 44 70

ONLINE PRIVATE LESSONS FOR SCIENCE STUDENTS
CALL OR WHATSAPP:689 45 44 70

Measuring I/O Performance

- I/O performance depends on
 - Hardware: CPU, memory, controllers, buses
 - Software: operating system, database management system, application
 - Workload: request rates and patterns
- I/O system design can trade-off between response time and throughput
 - Measurements of throughput often done with

The logo for Cartagena99, featuring the text 'Cartagena99' in a stylized font with a blue and orange gradient background.

CLASES PARTICULARES, TUTORÍAS TÉCNICAS ONLINE
LLAMA O ENVÍA WHATSAPP: 689 45 44 70

ONLINE PRIVATE LESSONS FOR SCIENCE STUDENTS
CALL OR WHATSAPP:689 45 44 70

I/O vs. CPU Performance

- Amdahl's Law
 - Don't neglect I/O performance as parallelism increases compute performance
- Example
 - Benchmark takes 90s CPU time, 10s I/O time
 - Double the number of CPUs/2 years
 - I/O unchanged

Year	CPU time	I/O time	Elapsed time	% I/O time
now	90s	10s	100s	10%
+2	45s	10s	55s	18%



CLASES PARTICULARES, TUTORÍAS TÉCNICAS ONLINE
 LLAMA O ENVÍA WHATSAPP: 689 45 44 70

 ONLINE PRIVATE LESSONS FOR SCIENCE STUDENTS
 CALL OR WHATSAPP:689 45 44 70

I/O System Design

- Satisfying latency requirements
 - For time-critical operations
 - If system is unloaded
 - Add up latency of components
- Maximizing throughput
 - Find “weakest link” (lowest-bandwidth component)
 - Configure to operate at its maximum bandwidth
 - Balance remaining components in the system
- If system is loaded, simple analysis is insufficient

Cartagena99

CLASES PARTICULARES, TUTORÍAS TÉCNICAS ONLINE
LLAMA O ENVÍA WHATSAPP: 689 45 44 70

ONLINE PRIVATE LESSONS FOR SCIENCE STUDENTS
CALL OR WHATSAPP:689 45 44 70

Server Computers

- Applications are increasingly run on servers
 - Web search, office apps, virtual worlds, ...
- Requires large data center servers
 - Multiple processors, networks connections, massive storage
 - Space and power constraints
- Server equipment built for 19" racks



CLASES PARTICULARES, TUTORÍAS TÉCNICAS ONLINE
LLAMA O ENVÍA WHATSAPP: 689 45 44 70

ONLINE PRIVATE LESSONS FOR SCIENCE STUDENTS
CALL OR WHATSAPP:689 45 44 70

Rack-Mounted Servers



Sun Fire x4150 1U server



2 Redundant
power Supplies

3 PCI Express Slots



Management NIC

2 USB Ports

Cartagena99

CLASES PARTICULARES, TUTORÍAS TÉCNICAS ONLINE
LLAMA O ENVÍA WHATSAPP: 689 45 44 70

ONLINE PRIVATE LESSONS FOR SCIENCE STUDENTS
CALL OR WHATSAPP: 689 45 44 70

Sun Fire x4150 1U server

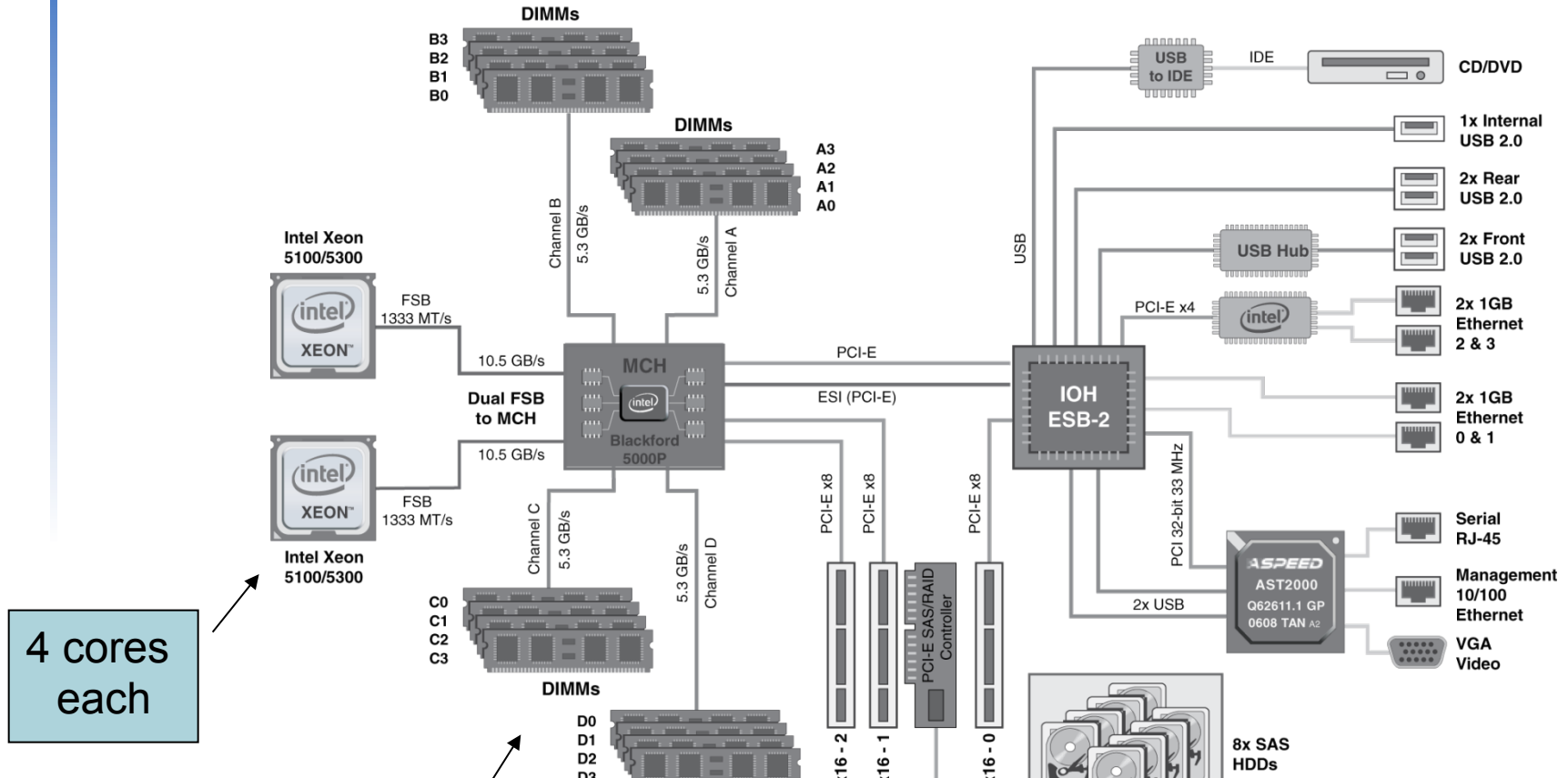

CLASES PARTICULARES, TUTORIAS TECNICAS ONLINE
 LLAMA O ENVIA WHATSAPP: 689 45 44 70

 ONLINE PRIVATE LESSONS FOR SCIENCE STUDENTS
 CALL OR WHATSAPP:689 45 44 70

Cartagena99

I/O System Design Example

- Given a Sun Fire x4150 system with
 - Workload: 64KB disk reads
 - Each I/O op requires 200,000 user-code instructions and 100,000 OS instructions
 - Each CPU: 10^9 instructions/sec
 - FSB: 10.6 GB/sec peak
 - DRAM DDR2 667MHz: 5.336 GB/sec
 - PCI-E 8× bus: $8 \times 250\text{MB/sec} = 2\text{GB/sec}$
 - Disks: 15,000 rpm, 2.9ms avg. seek time, 112MB/sec transfer rate
- What I/O rate can be sustained?

Cartagena99

CLASES PARTICULARES, TUTORÍAS TÉCNICAS ONLINE
LLAMA O ENVÍA WHATSAPP: 689 45 44 70

ONLINE PRIVATE LESSONS FOR SCIENCE STUDENTS
CALL OR WHATSAPP:689 45 44 70

Design Example (cont)

- I/O rate for CPUs
 - Per core: $10^9 / (100,000 + 200,000) = 3,333$
 - 8 cores: 26,667 ops/sec
- Random reads, I/O rate for disks
 - Assume actual seek time is average/4
 - Time/op = seek + latency + transfer
= $2.9\text{ms}/4 + 4\text{ms}/2 + 64\text{KB}/(112\text{MB/s}) = 3.3\text{ms}$
 - 303 ops/sec per disk, 2424 ops/sec for 8 disks
- Sequential reads

Cartagena99

CLASES PARTICULARES, TUTORÍAS TÉCNICAS ONLINE
LLAMA O ENVÍA WHATSAPP: 689 45 44 70

ONLINE PRIVATE LESSONS FOR SCIENCE STUDENTS
CALL OR WHATSAPP: 689 45 44 70

Design Example (cont)

- PCI-E I/O rate
 - $2\text{GB/sec} / 64\text{KB} = 31,250 \text{ ops/sec}$
- DRAM I/O rate
 - $5.336 \text{ GB/sec} / 64\text{KB} = 83,375 \text{ ops/sec}$
- FSB I/O rate
 - Assume we can sustain half the peak rate
 - $5.3 \text{ GB/sec} / 64\text{KB} = 81,540 \text{ ops/sec per FSB}$
 - $163,080 \text{ ops/sec for 2 FSBs}$
- Weakest link: disks
 - $2424 \text{ ops/sec random, } 14,000 \text{ ops/sec sequential}$

Cartagena99

CLASES PARTICULARES, TUTORÍAS TÉCNICAS ONLINE
LLAMA O ENVÍA WHATSAPP: 689 45 44 70

ONLINE PRIVATE LESSONS FOR SCIENCE STUDENTS
CALL OR WHATSAPP:689 45 44 70

Concluding Remarks

- I/O performance measures
 - Throughput, response time
 - Dependability and cost also important
- Buses used to connect CPU, memory, I/O controllers
 - Polling, interrupts, DMA
- I/O benchmarks
 - TPC, SPECSFS, SPECWeb

RAIN

Cartagena99

CLASES PARTICULARES, TUTORÍAS TÉCNICAS ONLINE
LLAMA O ENVÍA WHATSAPP: 689 45 44 70

ONLINE PRIVATE LESSONS FOR SCIENCE STUDENTS
CALL OR WHATSAPP:689 45 44 70